

THIS DRAWING IS UNPUBLISHED. RELEASED FOR PUBLICATION
 © COPYRIGHT - By - ALL RIGHTS RESERVED.

LOC		DIST		REVISIONS					
AJ		16		P	LTR	DESCRIPTION	DATE	DWN	APVD
				A1		ECR-12-005726	27MAR12	RK	MY

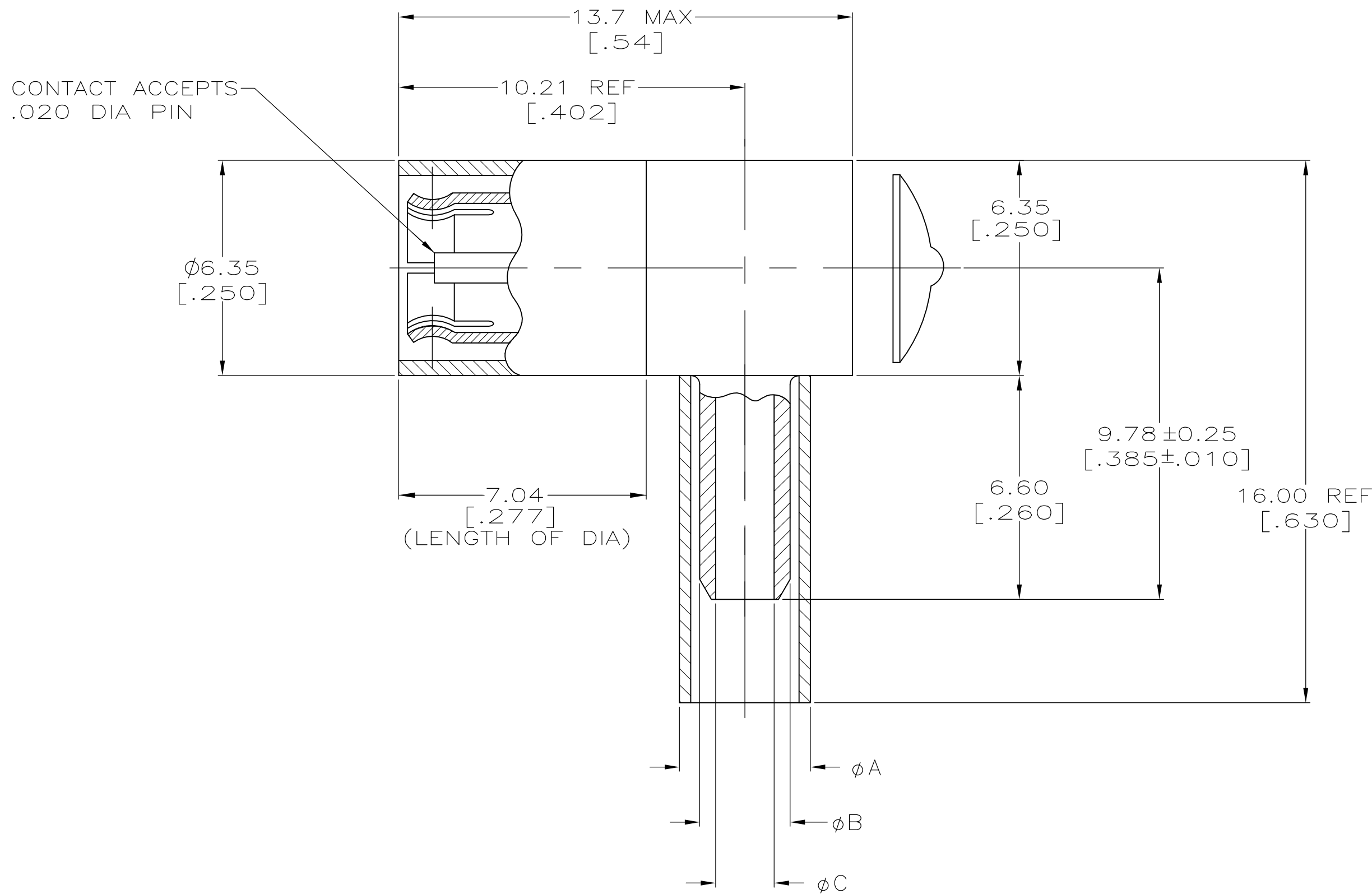

- 1 MATERIALS:
BODY: ZINC PER ASTM B 86.
CENTER CONTACT: BERYLLIUM COPPER PER ASTM B 194.
OUTER CONTACT: BERYLLIUM COPPER PER ASTM B 194.
DIELECTRIC: PTFE PER ASTM D 1710.
- 2 FINISHES:
BODY: NICKEL PER QQ-N-290.
CENTER CONTACT: GOLD PER ASTM B 488.
OUTER CONTACT: NICKEL PER QQ-N-290.
- 3 FINISHES:
BODY: NICKEL PER QQ-N-290.
CENTER CONTACT: GOLD PER ASTM B 488.
OUTER CONTACT: GOLD PER ASTM B 488.
- 4. DO NOT MATE WITH MIL-C-39012 CONNECTORS.
- 5 TOOLING INFORMATION:
BRAID CRIMP: HAND TOOL M-22520/5-01 WITH DANIELS DIE SET # HX4-1637 OR TE PRO-CRIMPER WITH DIE SET # 58483-1 (.128 HEX).
CENTER CONTACT: SOLDERED.
- 6 FOR USE WITH RG-179/U CABLE.
- 7. SEE INSTRUCTION SHEET 408-2987-9.
- 8 FOR USE WITH RG-179 DOUBLE-BRAIDED CABLE

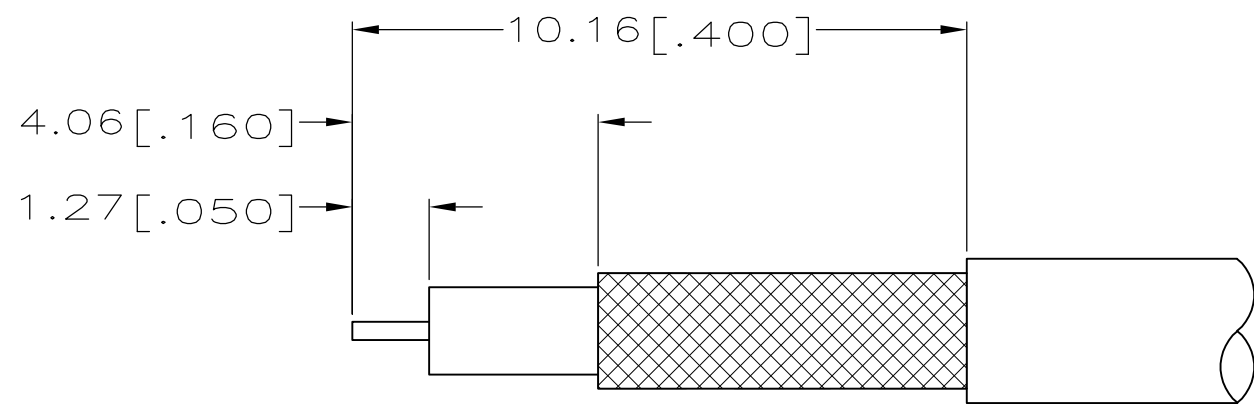

RECOMMENDED STRIP LENGTH

1.73 [.068]	2.64 [.104]	4.55 [.179]	8	5	3	5415484-3
1.73 [.068]	2.64 [.104]	3.86 [.152]	6	5	3	5415484-2
1.73 [.068]	2.64 [.104]	3.86 [.152]	6	5	2	5415484-1
φC ±0.08 [.003]	φB ±0.05 [.002]	φA ±0.05 [.002]	CABLE	TOOLING	FINISH	PART NUMBER

THIS DRAWING IS A CONTROLLED DOCUMENT.

DWN	J. HAVENER	31MAR2005
CHK	J. HAVENER	31MAR2005
APVD	J. HAVENER	31MAR2005
PRODUCT SPEC	NAME	
APPLICATION SPEC	PLUG, RIGHT ANGLE, 75 OHM, MINI-SMB	
WEIGHT	—	SIZE
CUSTOMER DRAWING	A2	CAGE CODE
	00779	DRAWING NO
	C=5415484	RESTRICTED TO
		SCALE
	8:1	SHEET
	1 OF 1	REV
		A1

TE Connectivity